



**JICTECH LCD (HONGKONG) CO.,LTD**  
**DONGGUAN JICTECH LCD CO.,LTD**  
**PROFESSIONAL LCM SUPPLIER**

## Product Specification For LCD Module

Model NO.: RT280A4004

REVISION: 1.0

- APPROVAL FOR SPECIFICATIONS ONLY  
 APPROVAL FOR SPECIFICATIONS AND SAMPLE

**CUSTOMER:**

**APPROVED BY:**

### LCM R&D CENTER

APPROVED BY	CHECKED BY	PREPARED BY
LHS	LuoXian	ZW CHEN



---

## Contents

1	Introduction-----	4
2	General specification-----	5
3	Mechanical drawing-----	6
4	Absolute maximum ratings-----	7
5	Electrical characteristics-----	7
6	Optical characteristics -----	8
7	Pin Assignment -----	11
8	Block diagram -----	12
9	Standard Specification for Reliability-----	13
10	Specification of Quality Assurance-----	15
11	Handling Precaution-----	23
12	Packing method-----	24

---

## 1. Introduction

### 1.1 Scope of application

This specification applies to the Negative type TFT transmissive dot matrix LCD module that is supplied by **LCD Co. , Ltd.** . This LCD module should be designed for mobile phone use.

LCD specification: Dots 240xRGBx320.

As to basic specification of the driver IC, refer to the IC (ILI9341V ) specification and datasheet.

### 1.2 Structure:

Double display structure:

TFT LCD + FPC + BL

2.8 inch TFT LCD size for main LCD;

One bare chip with gold bump (COG) TECH;

RGB 18 BITS+SPI interface;

### 1.3 TFT features:

Structure: TFT PANNEL+IC+FPC+BL;

Transmissive Type LCD

240 dot-source and 320 dot-gate outputs;

White LED back light;

### 1.4 Applications:

Mobile phone

PSP

PDA

GPS

Etc...

---

## 2. General specification

ITEM	Standard value	UNIT
LCD Type	TFT Transmissive	---
Driver element	a-Si TFT Active matrix	
Number of Dots	240*(RGB)*320	Dots
Pixel Arrangement	RGB Vertical Stripe	
Active Area	43.2(w) *57.6(h)	mm
Viewing Area (W*H)	/	mm
Viewing Direction	6 O'clock	
Driver IC	ILI9341V	
Module Size(W*H*T)	50x69.2x2.7	mm
Approx. Weight	TBD	g
Back Light	4 White LED	
System interface	RGB 18BIT+SPI	



## 4. ABSOLUTE MAXIMUM RATINGS

Parameter	Symbol	Min	Max	Unit
Supply voltage for logic	$V_{CC}$	-0.3	3.3	V
Input voltage for logic	$V_{IN}$	-0.5	$V_{CC} + 0.3$	V
Supply current (One LED)	$I_{LED}$		30	mA
Operating temperature	$T_{OP}$	-20	+70	°C
Storage temperature	$T_{ST}$	-30	+80	°C

## 5. ELECTRICAL CHARACTERISTICS

Item	Symbol	Min	Typ	Max	Unit	Applicable terminal
Supply voltage for logic	$V_{CC}$	2.5	2.8	3.3	V	$V_{DD}$
Input voltage	$V_{IL}$	-0.3	-	$0.2 V_{DD}$	V	
	$V_{IH}$	$0.8 V_{CC}$	-	$V_{CC}$	V	
Input leakage current	$I_{LKG}$				μA	
LED Forward voltage	$V_f$	3.0	3.2	3.4	V	--
Input backlight current	$I_{LED}$	-	15	20	mA	With One LED

**NOTE:**the LED is made by Harvatek. Bin range of luminous intensity: min 350mcd, Max 400mcd, grade B.

## 6. OPTICAL CHARACTERISTICS

ITEM	SYMBOL	CONDITIONS	SPECIFICATIONS			UNIT	NOTE	
			MIN.	TYP.	MAX			
Brightness	B	Viewing normal angle	315	350	--	cd/m <sup>2</sup>	All left side data are based on CPT's product reference only	
Contrast Ratio	CR			300	--	--		
Response Time	Tr+Tf			25		ms		
CIE Color coordinate	Red		X <sub>R</sub>	0.55	0.58	0.61		
			Y <sub>R</sub>	0.35	0.37	0.39		
	Green		X <sub>G</sub>	0.28	0.3	0.32		
			Y <sub>G</sub>	0.62	0.64	0.66		
	Blue		X <sub>B</sub>	0.13	0.15	0.18		
			Y <sub>B</sub>	0.05	0.07	0.1		
White	X <sub>w</sub>		0.12	0.15	0.18			
	Y <sub>w</sub>	0.05	0.07	0.09				
Viewing Angle	Hor.	$\theta_{x+}$		50	--	Deg.		
		$\theta_{x-}$		60	--			
	Ver.	$\theta_{y+}$		55	--			
		$\theta_{y-}$		60				
Uniformity	Un			85	%			

Note 1 : Definition of Viewing Angle  $\theta_x$  and  $\theta_y$  :

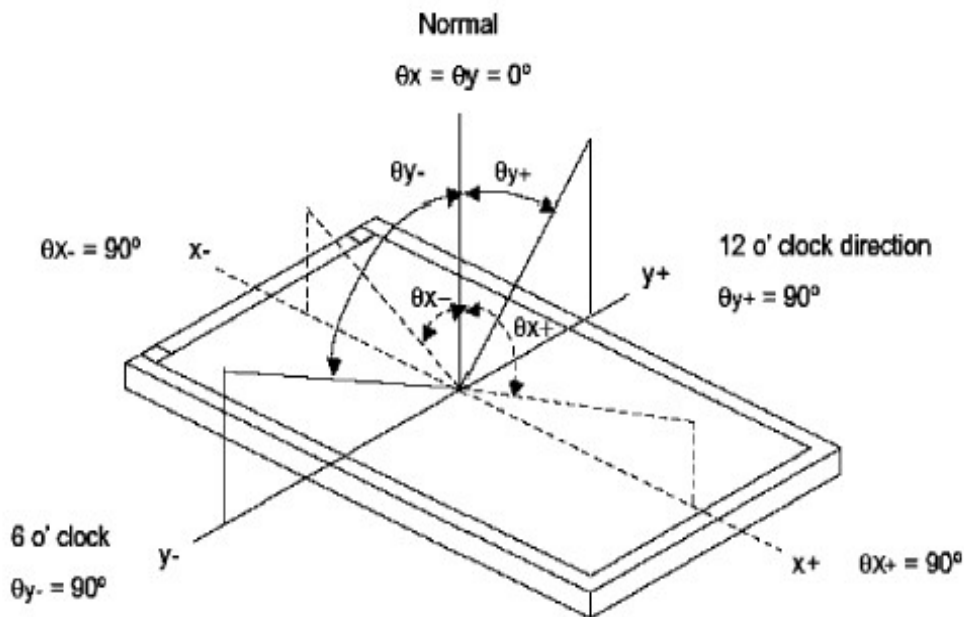

Note 2: Definition of contrast ratio CR:

$$CR = \frac{\text{Brightness of non-selected dots (white)}}{\text{Brightness of selected dots (black)}}$$

Note 3: Definition of response time ( $T_R$ ,  $T_F$ )

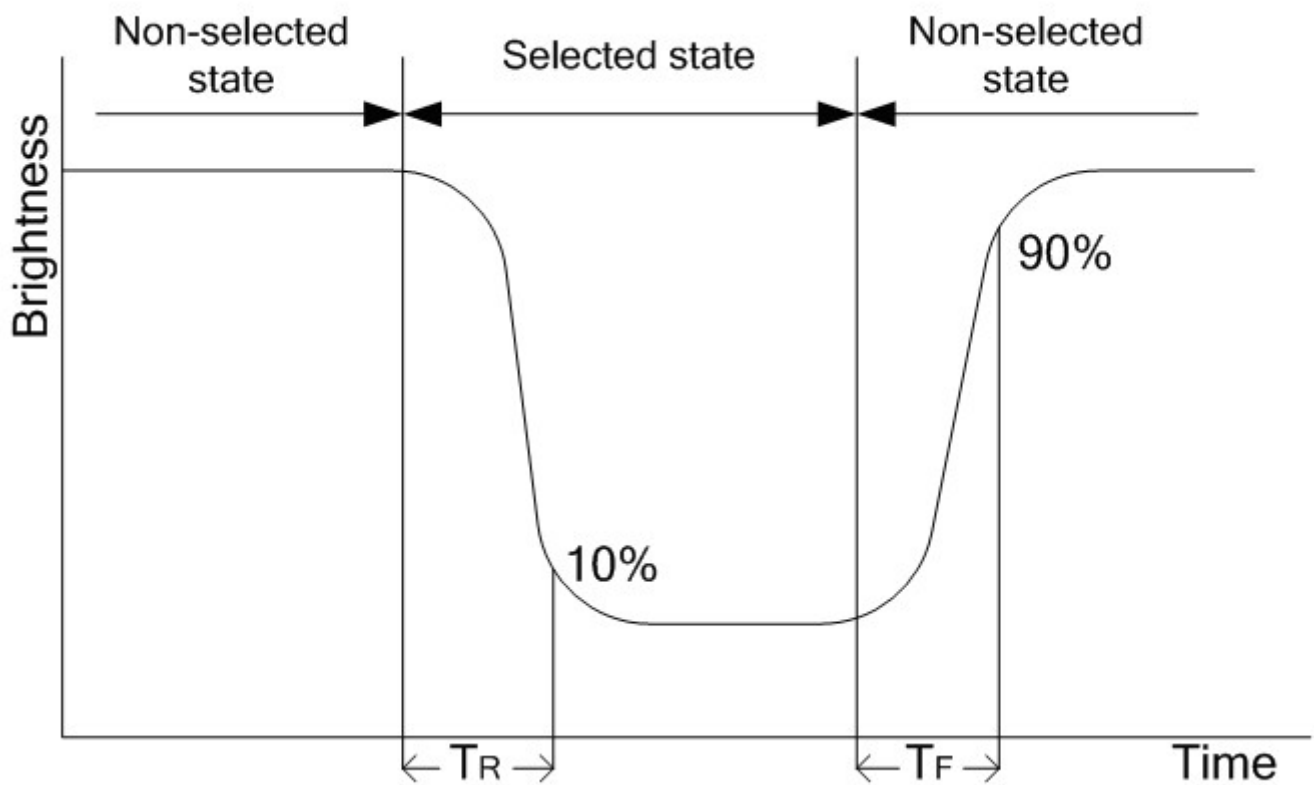

The brightness test equipment setup

20mA Field=2° (As measuring "black" image, field=2° is the best testing condition)

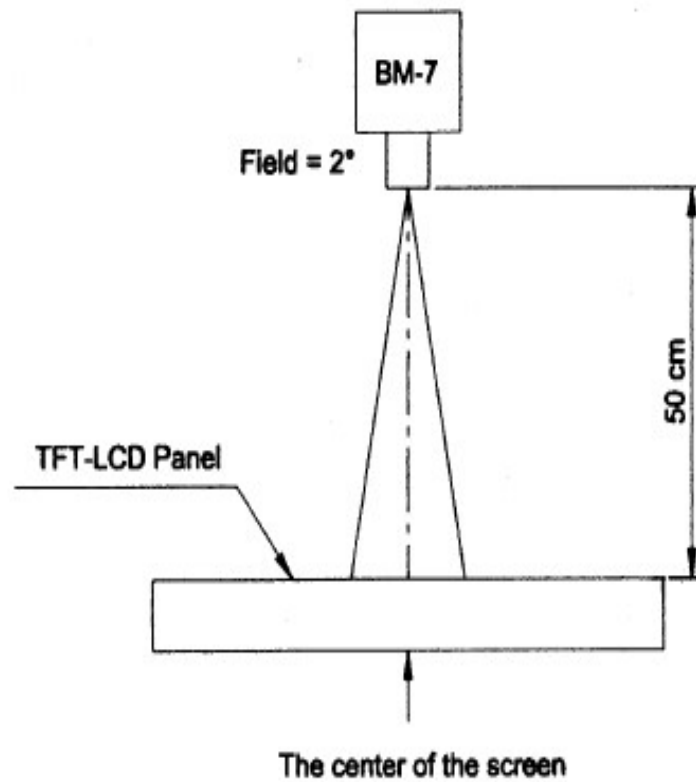

Note 4 :

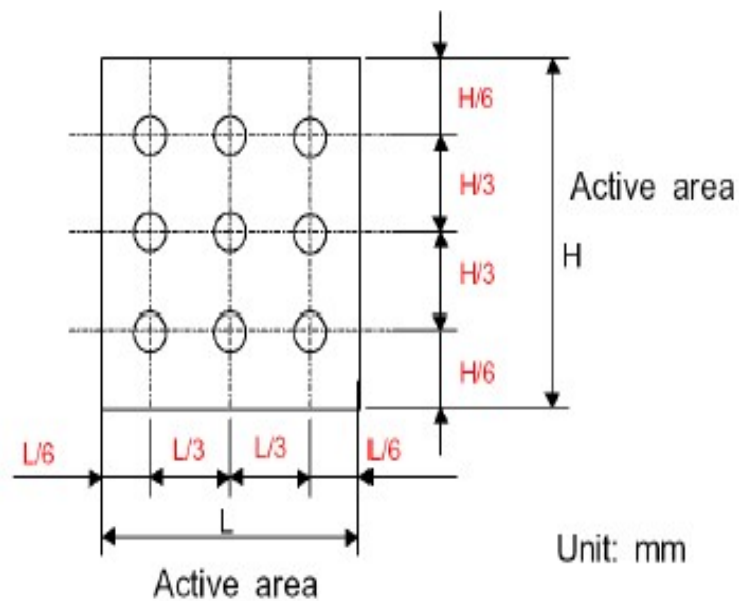

## 7. Interface Pin Function

. Table 2: Pin assignment

Pin No.	Symbol	Description
1	GND	Ground.
2	LEDA	Anode of LED backlight.
3-6	LEDK1- LEDK4	Cathode of LED backlight.
7	XR	NC
8	YU	NC
9	XL	NC
10	YD	NC
11	RESET	Reset(Low active)
12	VSYNC	Vertical sync. in RGB mode
13	HSYNC	Horizontal sync. in RGB mode
14	DOTCLK	Pixel clock signal in RGB mode
15	ENABLE	Data enable in RGB mode
16-21	R0-R5	Data bus for R0-R5
22-27	G0-G5	Data bus for G0-G5
28-33	B0-B5	Data bus for B0-B5
34	SDO	Serial data output
35	SDI/SDA	Serial data input
36	SCL	Serial interface clock
37	CS	A chip select signal. Low: the ILI9341V is selected and accessible. High: the ILI9341V is not selected and not accessible.
38	IOVCC	Power supply for analog voltage.(1.8V2.8V)
39	VCC	Power supply(2.8V)
40	GND	Ground.

## 8. BLOCK DIAGRAM

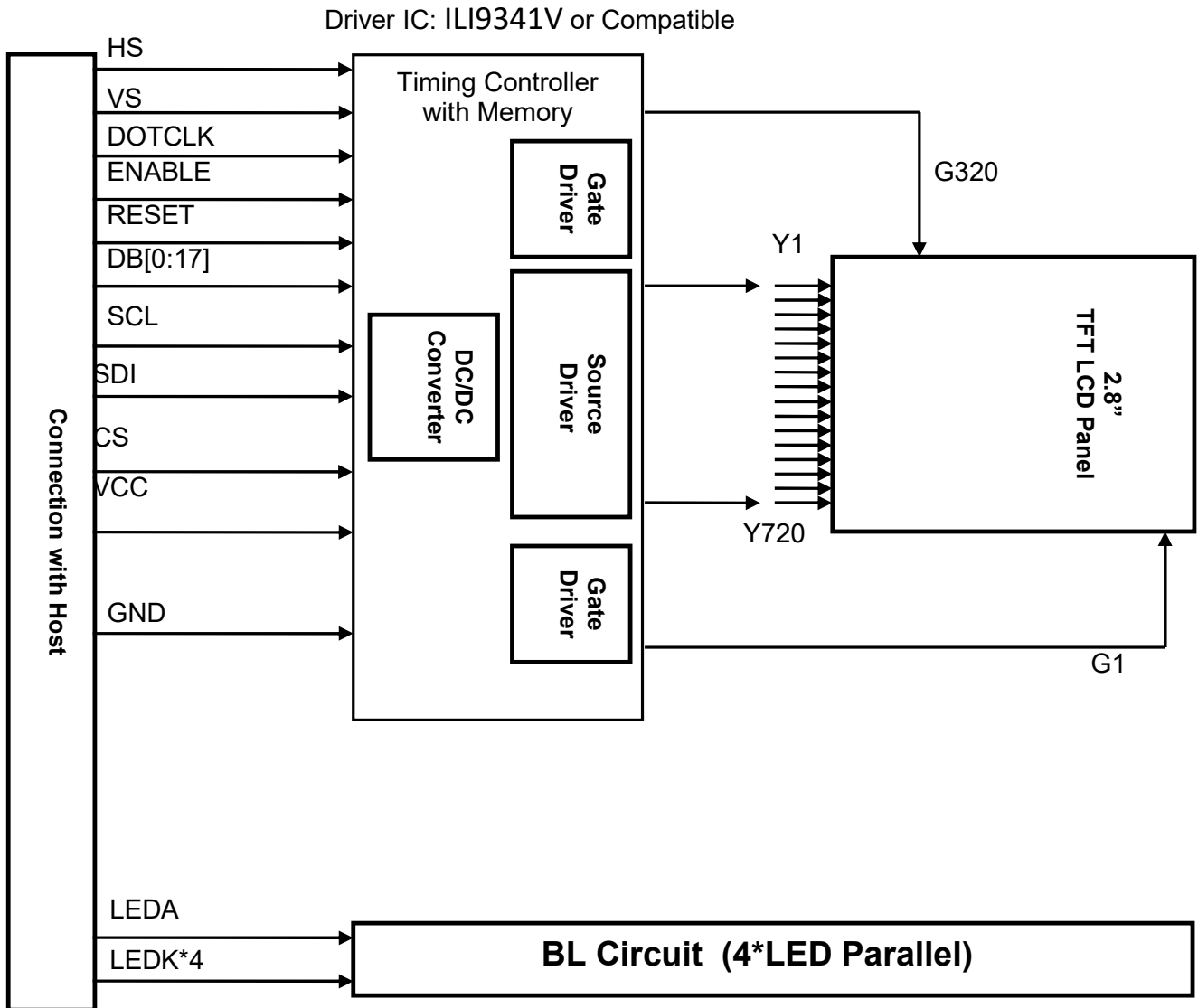

## 9. Standard Specification for Reliability

### 9-1. Standard Specifications for Reliability of LCD Module

No	Item	Description
01	High temperature operation	The sample should be allowed to stand at 60°C for 120 hours under driving condition and then returning it to normal temperature condition, and allowing it stand for 2 hours.
02	Low temperature operation	The sample should be allowed to stand at -10°C for 120 hours under driving condition and then returning it to normal temperature condition, and allowing it stand for 2 hours.
03	High temperature storage	The sample should be allowed to stand at 70°C for 240 hours under no-load condition, and then returning it to normal temperature condition, and allowing it stand for 2 hours.
04	Low temperature storage	The sample should be allowed to stand at -20°C for 240 hours under no-load condition, then returning it to normal temperature condition, and allowing it stand for 2 hours.
05	Moisture storage	The sample should be allowed to stand at 60°C,90%RH MAX for 240 hours under no-load condition, then taking it out and drying it at normal temperature for 2 hours.
06	Thermal shock storage	The sample should be allowed to stand the following 10 cycles : -30°C for 30 minutes → normal temperature for 5 minutes → +80°C for 30 minutes → normal temperature for 5 minutes, as one cycle.
07	Packing vibration	Frequency range : 10Hz ~ 55Hz Amplitude of vibration : 1.5mm Sweep time: 12 min X,Y,Z 2 hours for each direction.
08	Packing drop test	According to ASTM-D-5327.
09	Electrical Static Discharge	Air: ±4KV 150pF/330Ω 5 times
		Contact: ±2KV 150pF/330Ω 5 time

\*Sample size for each test item is 3~5pcs

For the final test the testing sample must be stored at room temperature for 24 hours, after the tests listed in Table 9.2, Standard specifications for Reliability have been executed in order to ensure stability.

No	Item	Test Model	In section Criteria
01	Current Consumption	Refer To Specification	The current consumption should conform to the product specification.
02	Contrast	Refer To Specification	After the tests have been executed, the contrast must be larger than half of its initial value prior to the tests.
03	Appearance	Visual inspection	Defect free.

### 9- 3. MTBF

MTBF	Functions, performance, appearance, etc. shall be free from remarkable deterioration within 50,000 hours under ordinary operating and storage conditions room temperature (25±5°C), normal humidity (50±10% RH), and in area not exposed to direct sun light.
------	---

---

## 10. Specification of Quality Assurance:

### 10-1. Purpose

This standard for Quality Assurance should affirm the quality of LCD module products to supply to purchaser by JIC TECHLCD

### 10-2. Standard for Quality Test

#### a. Inspection:

Before delivering, the supplier should take the following tests, and affirm the quality of product.

#### b. Electro-Optical Characteristics:

According to the individual specification to test the product.

#### c. Test of Appearance Characteristics:

According to the individual specification to test the product.

#### d. Test of Reliability Characteristics:

According to the definition of reliability on the specification for testing products.

#### e. Delivery Test:

Before delivering, the supplier should take the delivery test.

(i) Test method: According to MIL-STD105E.General Inspection Level II take a single time.

(ii) The defects classify of AQL as following:

Major defect: AQL = 0.65

Minor defect: AQL = 2.5

Total defects: AQL = 2.5

### 10-3. Non- conforming Analysis & Deal With Manners

#### a. Non- conforming Analysis:

(i) Purchaser should supply the detail data of non- conforming sample and the non- conforming.

(ii) After accepting the detail data from purchaser, the analysis of non- conforming should be finished in two weeks.

(iii) If supplier can not finish analysis on time, must announce purchaser before 3 days.

#### b. Disposition of non- conforming:

(i) If find any product defect of supplier during assembly time, supplier must change the good product for every defect after recognition.

(ii) Both supplier and customer should analyze the reason and discuss the disposition of non- conforming when the reason of nonconforming is not sure.

### 10-4. Agreement items

Both sides should discuss together when the following problems happen.

a. There is any problem of standard of quality assurance, and both sides should think that must be modified.

b. There is any argument item which does not record in the standard of quality assurance.

c. Any other special problem.

10-5. Standard of The Product Appearance Test

a. Manner of appearance test:

- (i) The test must be under 20W × 2 or 40W fluorescent light, and the distance of view must be at 30±5cm.
- (ii) When test the model of transmissive product must add the reflective plate.
- (iii) The test direction is base on around 10° of vertical line.
- (iii) Temperature: 25±5°C Humidity: 60±10%RH

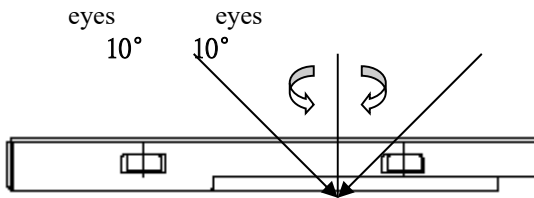

(iv) Definition of area:

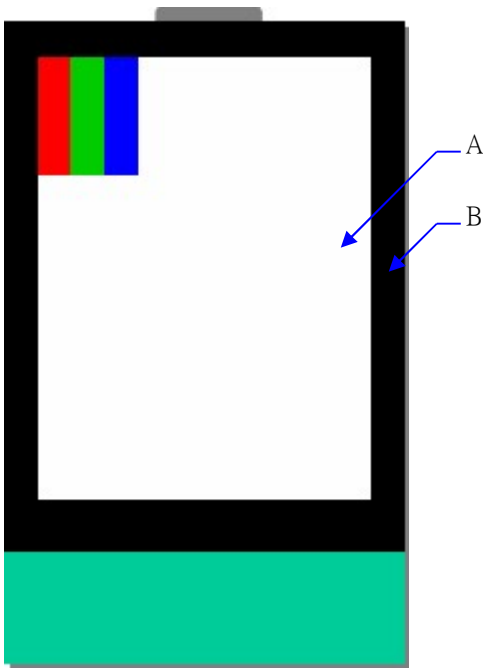

A. Area: Viewing area.

B. Area: Out of viewing area.

(Outside viewing area)

b. Basic principle:

- (i) It will accord to the AQL when the standard can not be described.
- (ii) The sample of the lowest acceptable quality level must be discussed by both supplier and customer when any dispute happened.
- (iii) Must add new item on time when it is necessary.

c. Standard of inspection: (Unit: mm)

10-6. Inspection specification

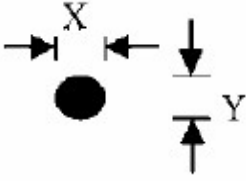
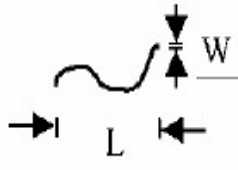
NO	Item	Criterion	AQL												
01	Electrical Testing	1.1 Missing vertical, horizontal segment, segment contrast defect. 1.2 Missing character, dot or icon. 1.3 Display malfunction. 1.4 No function or no display. 1.5 Current consumption exceeds product specifications. 1.6 LCD viewing angle defect. 1.7 Mixed product types. 1.8 Flicker	0.65												
02	Black or White spots or Bright spots or Color spots on LCD (Display only)	2.1 White and black or color spots on display $\leq 0.25\text{mm}$ , no more than Five spots. 2.2 Densely spaced: No more than three spots within 3mm.	2.5												
03	LCD and Touch Panel black spots, white spots, contamination (non – display)	3.1 Round type: As following drawing $\Phi = (X+Y) / 2$  <table border="1" data-bbox="758 896 1284 1108"> <thead> <tr> <th>Size(mm)</th> <th>Acceptable Q'ty</th> </tr> </thead> <tbody> <tr> <td><math>\Phi \leq 0.10</math></td> <td>Accept no dense</td> </tr> <tr> <td><math>0.10 &lt; \Phi \leq 0.20</math></td> <td>2</td> </tr> <tr> <td><math>0.20 &lt; \Phi \leq 0.25</math></td> <td>2</td> </tr> <tr> <td><math>0.25 &lt; \Phi \leq 0.30</math></td> <td>1</td> </tr> <tr> <td><math>0.30 &lt; \Phi</math></td> <td>0</td> </tr> </tbody> </table> <p style="text-align: right;">* Densely spaced: No more than two spots within 3mm.</p>	Size(mm)	Acceptable Q'ty	$\Phi \leq 0.10$	Accept no dense	$0.10 < \Phi \leq 0.20$	2	$0.20 < \Phi \leq 0.25$	2	$0.25 < \Phi \leq 0.30$	1	$0.30 < \Phi$	0	2.5
		Size(mm)	Acceptable Q'ty												
$\Phi \leq 0.10$	Accept no dense														
$0.10 < \Phi \leq 0.20$	2														
$0.20 < \Phi \leq 0.25$	2														
$0.25 < \Phi \leq 0.30$	1														
$0.30 < \Phi$	0														
3.2 Line type: (As following drawing)  <table border="1" data-bbox="662 1220 1284 1433"> <thead> <tr> <th>Length(m)</th> <th>Width(mm)</th> <th>Acceptable Q'ty</th> </tr> </thead> <tbody> <tr> <td>---</td> <td><math>W \leq 0.02</math></td> <td>Accept no dense</td> </tr> <tr> <td><math>L \leq 3.0</math></td> <td><math>0.02 &lt; W \leq 0.05</math></td> <td rowspan="2">2</td> </tr> <tr> <td><math>L \leq 2.5</math></td> <td><math>0.03 &lt; W \leq 0.08</math></td> </tr> <tr> <td>---</td> <td><math>0.08 &lt; W</math></td> <td>Rejection</td> </tr> </tbody> </table> <p style="text-align: right;">* Densely spaced: No more than two lines within 3mm.</p>	Length(m)	Width(mm)	Acceptable Q'ty	---	$W \leq 0.02$	Accept no dense	$L \leq 3.0$	$0.02 < W \leq 0.05$	2	$L \leq 2.5$	$0.03 < W \leq 0.08$	---	$0.08 < W$	Rejection	2.5
Length(m)	Width(mm)	Acceptable Q'ty													
---	$W \leq 0.02$	Accept no dense													
$L \leq 3.0$	$0.02 < W \leq 0.05$	2													
$L \leq 2.5$	$0.03 < W \leq 0.08$														
---	$0.08 < W$	Rejection													

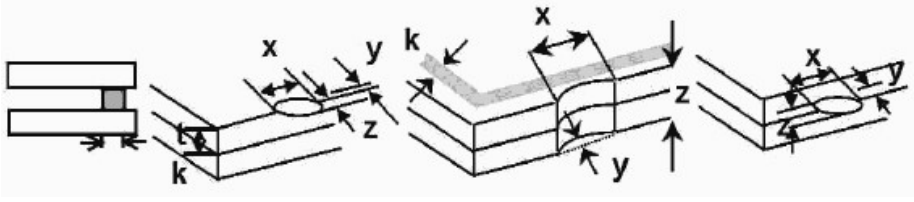
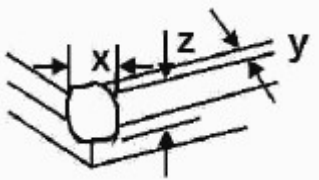
NO	Item	Criterion	AQL																		
04	Polarizer bubbles	<p>If bubbles are visible, judge using black spot specifications, not easy to find, must check in specify direction</p> <table border="1" data-bbox="790 302 1284 504"> <thead> <tr> <th>Size <math>\Phi</math>(mm)</th> <th>Acceptable Q'ty</th> </tr> </thead> <tbody> <tr> <td><math>\Phi \leq 0.20</math></td> <td>Accept no dense</td> </tr> <tr> <td><math>0.20 &lt; \Phi \leq 0.50</math></td> <td>3</td> </tr> <tr> <td><math>0.50 &lt; \Phi \leq 1.00</math></td> <td>2</td> </tr> <tr> <td><math>1.00 &lt; \Phi</math></td> <td>0</td> </tr> <tr> <td>Total Q'ty</td> <td>3</td> </tr> </tbody> </table>	Size $\Phi$ (mm)	Acceptable Q'ty	$\Phi \leq 0.20$	Accept no dense	$0.20 < \Phi \leq 0.50$	3	$0.50 < \Phi \leq 1.00$	2	$1.00 < \Phi$	0	Total Q'ty	3	2.5						
Size $\Phi$ (mm)	Acceptable Q'ty																				
$\Phi \leq 0.20$	Accept no dense																				
$0.20 < \Phi \leq 0.50$	3																				
$0.50 < \Phi \leq 1.00$	2																				
$1.00 < \Phi$	0																				
Total Q'ty	3																				
05	Scratches	Follow NO.3 -2 Line Type.																			
06	Chipped glass	<p>Symbols:  x: Chip length    y: Chip width    z: Chip thickness  k: Seal width    t: Glass thickness    a: LCD side length  L: Electrode pad length</p> <p>6.1 General glass chip:  6.1.1 Chip on panel surface and crack between panels:</p>  <table border="1" data-bbox="335 940 1157 1041"> <thead> <tr> <th>z: Chip thickness</th> <th>y: Chip width</th> <th>x: Chip length</th> </tr> </thead> <tbody> <tr> <td><math>Z \leq 1/2t</math></td> <td>Not over viewing area</td> <td><math>x \leq 1/8a</math></td> </tr> <tr> <td><math>1/2t &lt; z \leq 2t</math></td> <td>Not exceed 1/3k</td> <td><math>x \leq 1/8a</math></td> </tr> </tbody> </table> <p>⊙ Unit: mm  ⊙ If there are 2 or more chips, x is the total length of each chip</p> <p>6.1.2 Corner crack:</p>  <table border="1" data-bbox="335 1377 1157 1478"> <thead> <tr> <th>z: Chip thickness</th> <th>y: Chip width</th> <th>x: Chip length</th> </tr> </thead> <tbody> <tr> <td><math>Z \leq 1/2t</math></td> <td>Not over viewing area</td> <td><math>x \leq 1/8a</math></td> </tr> <tr> <td><math>1/2t &lt; z \leq 2t</math></td> <td>Not exceed 1/3k</td> <td><math>x \leq 1/8a</math></td> </tr> </tbody> </table> <p>⊙ Unit: mm  ⊙ If there are 2 or more chips, x is the total length of each chip</p>	z: Chip thickness	y: Chip width	x: Chip length	$Z \leq 1/2t$	Not over viewing area	$x \leq 1/8a$	$1/2t < z \leq 2t$	Not exceed 1/3k	$x \leq 1/8a$	z: Chip thickness	y: Chip width	x: Chip length	$Z \leq 1/2t$	Not over viewing area	$x \leq 1/8a$	$1/2t < z \leq 2t$	Not exceed 1/3k	$x \leq 1/8a$	2.5
z: Chip thickness	y: Chip width	x: Chip length																			
$Z \leq 1/2t$	Not over viewing area	$x \leq 1/8a$																			
$1/2t < z \leq 2t$	Not exceed 1/3k	$x \leq 1/8a$																			
z: Chip thickness	y: Chip width	x: Chip length																			
$Z \leq 1/2t$	Not over viewing area	$x \leq 1/8a$																			
$1/2t < z \leq 2t$	Not exceed 1/3k	$x \leq 1/8a$																			

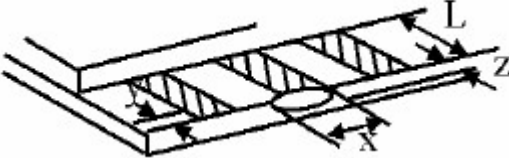
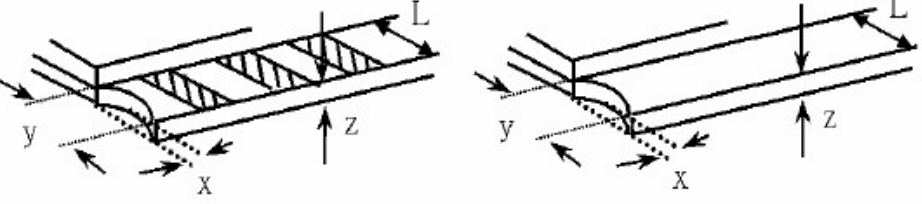
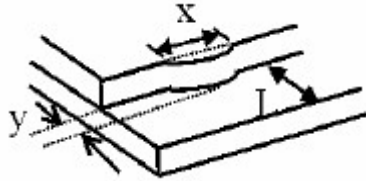
NO	Item	Criterion	AQL																
07	Glass crack	<p>Symbols:  x: Chip length    y: Chip width    z: Chip thickness  k: Seal width    t: Glass thickness    a: LCD side length  L: Electrode pad length</p> <p>7.2 Protrusion over terminal:  7.2.1 Chip on electrode pad:</p>  <table border="1" data-bbox="470 645 1145 790"> <tr> <td>y: Chip width</td> <td>x: Chip length</td> <td>z: Chip thickness</td> </tr> <tr> <td><math>y \leq 0.5\text{mm}</math></td> <td><math>x \leq 1/8a</math></td> <td><math>0 &lt; z \leq t</math></td> </tr> </table> <p>7.2.2  Non-conductive portion:</p>  <table border="1" data-bbox="470 1115 1145 1261"> <tr> <td>y: Chip width</td> <td>x: Chip length</td> <td>z: Chip thickness</td> </tr> <tr> <td><math>y \leq L</math></td> <td><math>x \leq 1/8a</math></td> <td><math>0 &lt; z \leq t</math></td> </tr> </table> <p>⊙ If there chipped area touches the ITO terminal, over 2/3 of the ITO must remain and be inspected according to electrode terminal specifications.  ⊙ If the product will be heat sealed by the customer, the alignment mark must not be damaged.</p> <p>7.2.3 Substrate protuberance and internal crack</p>  <table border="1" data-bbox="790 1496 1225 1637"> <tr> <td>y: width</td> <td>x: length</td> </tr> <tr> <td><math>y \leq 1/3L</math></td> <td><math>X \leq a</math></td> </tr> </table>	y: Chip width	x: Chip length	z: Chip thickness	$y \leq 0.5\text{mm}$	$x \leq 1/8a$	$0 < z \leq t$	y: Chip width	x: Chip length	z: Chip thickness	$y \leq L$	$x \leq 1/8a$	$0 < z \leq t$	y: width	x: length	$y \leq 1/3L$	$X \leq a$	2.5
y: Chip width	x: Chip length	z: Chip thickness																	
$y \leq 0.5\text{mm}$	$x \leq 1/8a$	$0 < z \leq t$																	
y: Chip width	x: Chip length	z: Chip thickness																	
$y \leq L$	$x \leq 1/8a$	$0 < z \leq t$																	
y: width	x: length																		
$y \leq 1/3L$	$X \leq a$																		

NO	Item	Criterion	AQL
----	------	-----------	-----

08	Cracked glass	The LCD with extensive crack is not acceptable.	2.5
09	Backlight elements	9.1 Illumination source flickers when lit. 9.2 Spots or scratches that appear when lit must be judged. Using LCD spot, lines and contamination standards. 9.3 Backlight doesn't light or color is wrong.	2.5 2.5 0.65
10	Bezel	Bezel must comply with product specifications.	2.5
11	PCB、COB	11.1 COB seal may not have pinholes larger than 0.2mm or contamination. 11.2 COB seal surface may not have pinholes through to the IC. 11.3 The height of the COB should not exceed the height indicated in the assembly diagram. 11.4 There may not be more than 2mm of sealant outside the seal area on PCB. And there should be no more than three places. 11.5 Parts on PCB must be the same as on the production characteristic chart, There should be no wrong parts, missing parts or excess parts. 11.6 The jumper on the PCB should conform to the product characteristic chart.	2.5 2.5 2.5 2.5 0.65 0.65
12	FPC	12.1 FPC terminal damage $\cong$ 1/2 FPC terminal width and can not affect the function , we judge accept. 12.2 FPC alignment hole damage $\cong$ 1/2 alignment area and can not affect the function , we judge accept.	2.5 2.5
13	Soldering	13.1 No cold solder joints, missing solder connections, oxidation or icicle. 13.2 No short circuits in components on PCB or FPC.	2.5 0.65

NO	Item	Criterion	AQL
----	------	-----------	-----

Symbols:

x: Chip length    y: Chip width    z: Chip thickness  
 k: Seal width    t: Touch Panel Total thickness    a: LCD side length  
 L: Electrode pad length

14.1 General glass chip:

14.1.1 Chip on panel surface and crack between panels:

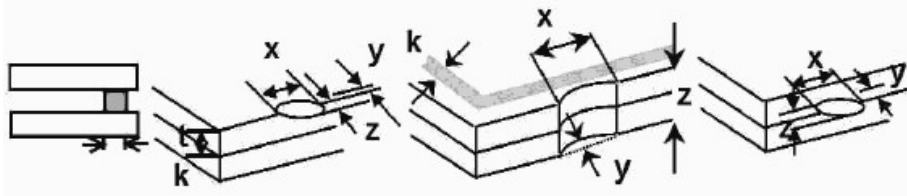

z: Chip thickness	y: Chip width	x: Chip length
$Z \leq t$	$\leq 1/2 k$ and not over viewing area	$x \leq 1/8a$

⊙ Unit: mm

⊙ If there are 2 or more chips, x is the total length of each chip

14.1.2 Corner crack:

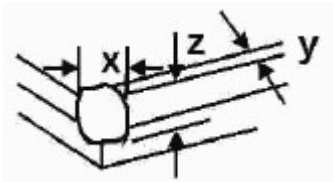

z: Chip thickness	y: Chip width	x: Chip length
$z \leq t$	$\leq 1/2 k$ and not over viewing area	$x \leq 1/8a$

⊙ Unit: mm

⊙ If there are 2 or more chips, x is the total length of each chip

14

Touch Panel  
Chipped glass

2.5

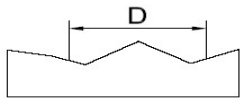
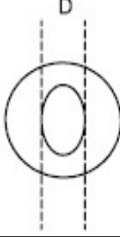
NO	Item	Criterion	AQL										
15	Touch Panel(Fish eye、dent and bubble on film)	<table border="1" data-bbox="335 280 869 459"> <thead> <tr> <th>SIZE(mm)</th> <th>Acceptable Q'ty</th> </tr> </thead> <tbody> <tr> <td><math>\Phi \leq 0.2</math></td> <td>Accept no dense</td> </tr> <tr> <td><math>0.2 &lt; D \leq 0.4</math></td> <td>5</td> </tr> <tr> <td><math>0.4 &lt; D \leq 0.5</math></td> <td>2</td> </tr> <tr> <td><math>0.5 &lt; D</math></td> <td>0</td> </tr> </tbody> </table>  	SIZE(mm)	Acceptable Q'ty	$\Phi \leq 0.2$	Accept no dense	$0.2 < D \leq 0.4$	5	$0.4 < D \leq 0.5$	2	$0.5 < D$	0	2.5
SIZE(mm)	Acceptable Q'ty												
$\Phi \leq 0.2$	Accept no dense												
$0.2 < D \leq 0.4$	5												
$0.4 < D \leq 0.5$	2												
$0.5 < D$	0												
16	Touch Panel Newton ring	Newton ring dimension $\leq 1/2$ touch panel area and not affect font and line distortion( $\leq 2.5\%$ ), it is acceptable.	2.5										
17	Touch Panel Linearity	Less than 2.5% is acceptable.	2.5										
18	LCD Ripple	Touch the touch panel , can not see the LCD ripple. Pen: R 1.0mm silicon rubber. Operation Force: 80g	2.5										
19	General appearance	19.1 Pin type must match type in specification sheet. 19.2 LCD pin loose or missing pins. 19.3 Product packaging must the same as specified on packaging specification sheet. 19.4 Product dimension and structure must conform to product specification sheet.	0.65 0.65 0.65 0.65										

---

## 11. Handling Precaution:

### 11-1 Handling of LCM

- Don't give external shock.
- Don't apply excessive force on the surface.
- Liquid in LCD is hazardous substance. Must not lick and swallow. when the liquid is attach to your hand, skin, cloth etc. Wash it out thoroughly and immediately.
- Don't operate it above the absolute maximum rating.
- Don't disassemble the LCM.
- The operators should be grounded whenever he/she comes into contact with the module. Never touch any of the conductive parts such as the LSI pads,the copper leads on the PCB and the interface terminals with any parts of the human body.
- The modules should be kept in antistatic bags or other containers resistant to static for storage.
- The module is coated with a film to protect the display surface. Be care when peeling off this protective film since static electricity may be generated.

### 11-2 Storage

- Store in an ambient temperature of  $25\pm 10^{\circ}\text{C}$ , and in a relative humidity of  $50\pm 10\%\text{RH}$ . Don't expose to sunlight or fluorescent light.
- Storage in a clean environment, free from dust, active gas, and solvent.
- Store in anti-static electricity container.
- Store without any physical load.

### 11-3 Soldering

- Use only soldering irons with proper grounding and no leakage.
- Iron: No higher than  $280\pm 10^{\circ}\text{C}$  and less than 3 sec during Hand soldering.
- Rewiring: no more than 2 times.

## 12. Packing method

### 12-1 Package description

A large box has 300PCS; A small box has 100PCS; A large box has 30 trays; A small box has 10 trays; A tray of 10PCS。

The thickness of 0.8MM is tray.

### 12-2 Package diagram

